

19" PANDORA SOHO PANDORA SLIM Series Wall Mounting Cabinets



19" PANDORA SOHO / PANDORA SLIM Series

Wall Mounting Cabinets

Compliance with standards:

- With the EN 12150-1 standard antistatic, smoked tempered safety glass 4,0 mm front glass door.
- Round quarter turn lock which is compatible with DIN 1743, DIN 53571, RoHS.
- EN IEC 60297- Mechanical constructions for electrical devices. mechanical constructions (19 inch series) with standard universal 482,6 mm profiles
- EN IEC 60917- Modular layout for development of mechanical constructions in electronic equipment applications.
- EIA/ ECA-310 (D/E) 19" 482,6 mm and U 44,45 mm Height Sizing
- EN 61587-1 For electronic devices inner usage mechanic construction cabinets, bottom shelves, cases, IEC 60917 and IEC 60297 series tests, Chapter 1, environmental conditions, test setup and security rules.
- Climatic and environment: EN 61587-1/4.2, IEC 60068-2-1, IEC 60068-2-2, IEC 60068-2-30
- Static Mechanical Load Lifting: EN 61587-1/5.2.1
- Static Mechanical Load Stiffness: EN 61587-1/5.2.2
- Dynamic mechanical load vibration and shock, impact: EN 61587-1/5.3.1, EN 61587-1/5.3.3, IEC 60068-2-6, IEC 60068-2-27
- Grounding: EN 61587-1/6.2
- Fireproofing: EN 61587-1/6.3
- IP protection class (IP code): IP20, EN 61587-1/6.4
- The powder paint used is non-flammable and has a flame-retardant resistant according to TS EN 13501-1 + A1 standard
- TS EN ISO 9227 corrosion tests, salt spraying tests, TS EN ISO 2409 paints and varnishes, cross cutting test, TS 2311 EN ISO2178 above magnetic metals non-magnetic covering, measuring covering thickness, magnetic method
- 2011/65/EU- regulation of hazardous material restriction/ RoHS suitability
- TS EN 60950-1 information technology devices, Security- Chapter 1
- General rules- CE suitability
- Sheet steel: DIN 934, DIN 985, DIN 933 - EN ISO 2081 metallic and other inorganic coverings covered above iron or steel with the additional process electrolytic zinc covering standards

Production Facility Standards

- ISO 9001- Quality Control System
- ISO 14001- Environmental Management System
- ISO 45001- Occupational Health and Safety Management System

PANDORA SOHO



PANDORA SLIM



19" PANDORA SOHO Series

Wall Mounting Cabinets

PANDORA SOHO wall mounting cabinets are designed for network distribution, where a fast efficient installation is required, providing a cost-effective solution.

Whilst the product provides maximum performance on cabling and networking installations, the unique design provides an economic solution compared to its quality which is based on high technology, fully automated production techniques .

19" PANDORA SOHO network cabinets specially designed for flat pack, for cost effective logistics plus fast efficient assembly.

Each cabinet is supplied as standard with a safety glass front door lockable with a barrel style keyed one point "O" locking unit.

The 19" cabinet supplied as W: 540 x D: 400 mm sizes, 4 different heights of 4U, 7U, 9U and 12U.

Completely standard and stocked product portfolio, being delivered as a single piece flat pack product, as standard shipping configuration 1 set: 2pieces 19" adjustable depth equipment mounting rails are included.



19" PANDORA SOHO Series

Wall Mounting Cabinets

Framework- Top/Bottom Cases:

Multi folded automated bending technology design for framework and top/bottom cases, this provides a heavy-duty structure which results in, a high load capacity of 60 kg's.

A fan module can be integrated or just single fan could be assembled directly.

Cable entry available in top and bottom case W: 145 mm x D: 70 mm sized PVC cabling insertions.

Removable PVC cable entry covering, with the option of brush strip cover to provide dust protection.

The full length smoked, shatterproof, antistatic, tempered, 4,0 mm thickness safety glass door with single point keyed locking barrel lock system integrated with "O" type locker.

Flexible front door opening direction is set right to left, but reversible to left to right at site with removing the hinge system. Hinge System is channel type with screws.

Available/stocked colour of PANDORA SOHO wall mounting cabinets are in RAL 7035 Light Grey, option of Black RAL 9005 colour paint if preferred, coordinate with sales department.



19" PANDORA SOHO Series

Width: 540 mm
Depth: 400 mm

Wall Mounting Cabinets

Construction Drawings

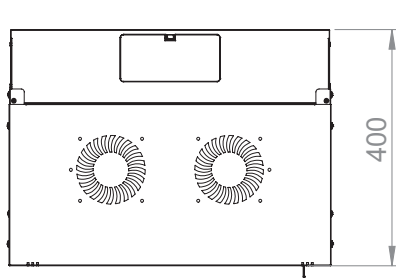

Top view

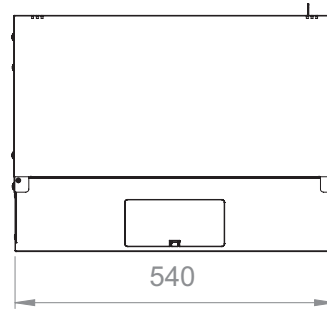

Bottom view

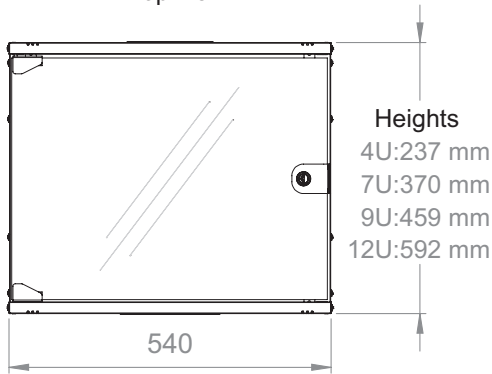

Front view

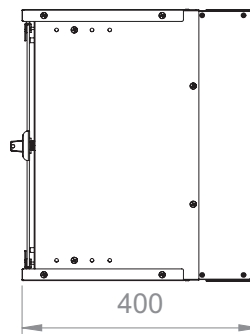

Side view

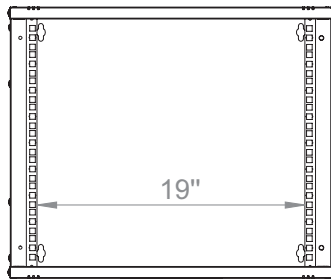

Front inside view

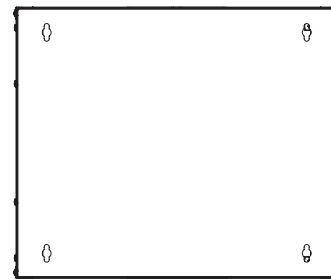

Rear view

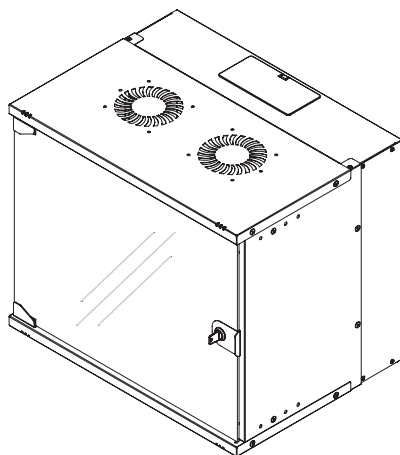

Isometric view

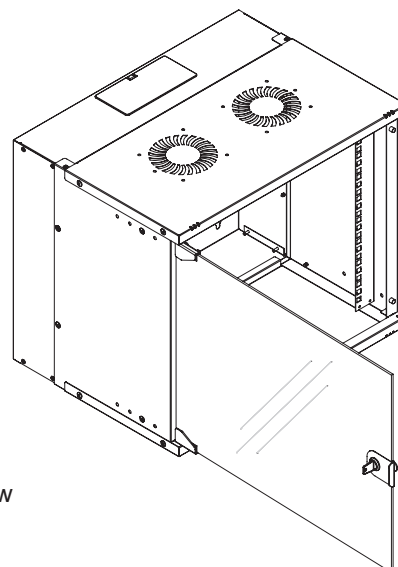

19" PANDORA SOHO Series

Width: 540 mm
Depth: 400 mm

Wall Mounting Cabinets

Construction Drawings

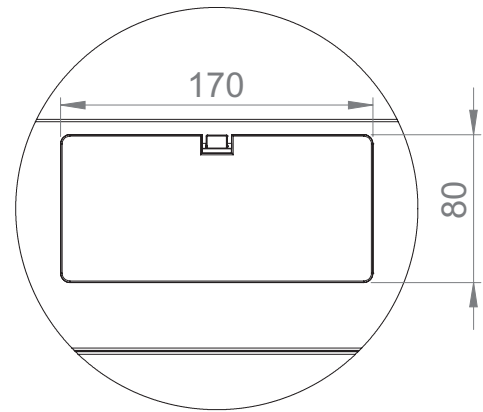
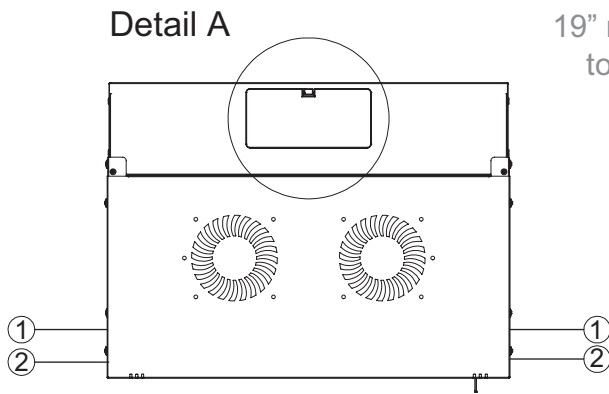

Detail A

Factory preconfigured assembly of 19" rail position is shown in number 2

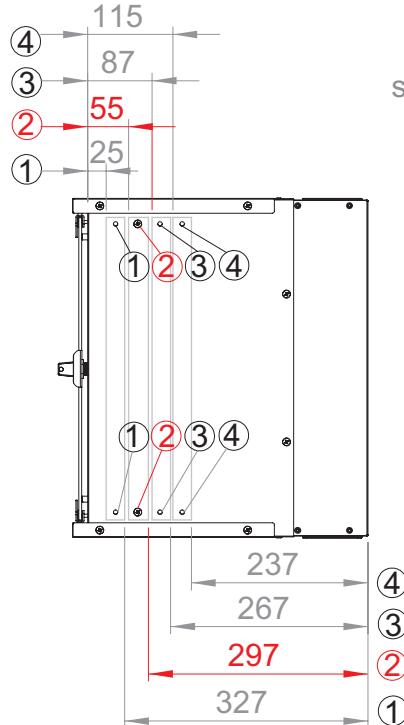

19" mounting side view dimensions and steps

② Depth measurement at factory pre-configuration

19" PANDORA SOHO Series

Width: 540 mm
Depth: 400 mm

Wall Mounting Cabinets

Construction Drawings

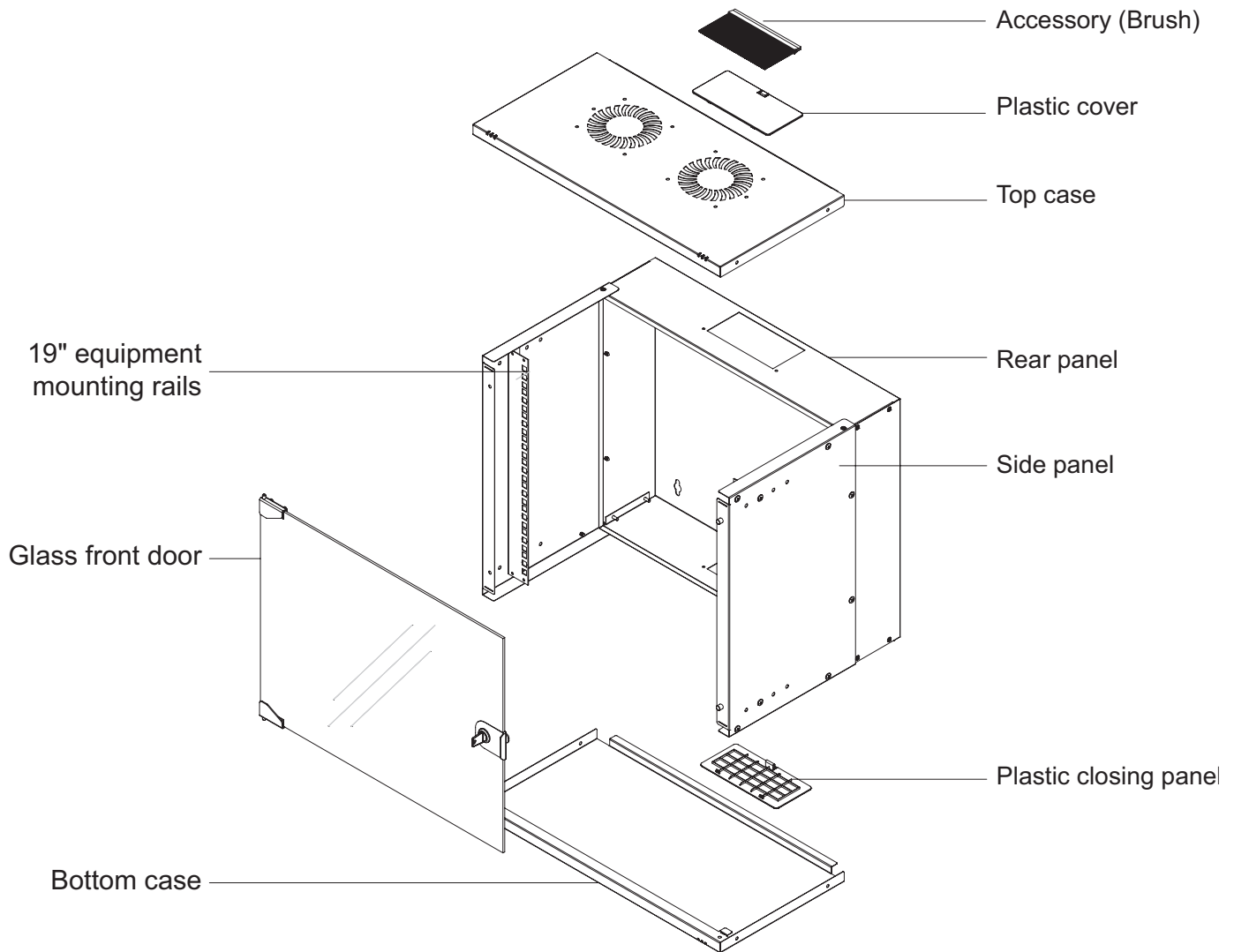

19" PANDORA SOHO Series Wall Mounting Cabinets W=540 mm D=400 mm Flat Pack

Product Code*	Series	Product Description	Dimensions WxDxH mm	h size in U	h mm
LN-SX04U5440-LG	PANDORA SOHO Series	4U 19" PANDORA SOHO Wall Mounting Cabinet W=540 mm D=400 mm	540x400x237	4U	178
LN-SX07U5440-LG	PANDORA SOHO Series	7U 19" PANDORA SOHO Wall Mounting Cabinet W=540 mm D=400 mm	540x400x370	7U	311
LN-SX09U5440-LG	PANDORA SOHO Series	9U 19" PANDORA SOHO Wall Mounting Cabinet W=540 mm D=400 mm	540x400x459	9U	400
LN-SX12U5440-LG	PANDORA SOHO Series	12U 19" PANDORA SOHO Wall Mounting Cabinet W=540 mm D=400 mm	540x400x592	12U	533

* Cabinet is RAL 7035 Light Grey.

** The product is only shipped flat pack. There is no assembled shipment option.



19" PANDORA SOHO Series

Width: 540 mm
Depth: 400 mm

Wall Mounting Cabinets

Accessories

Horizontal Cable Management

Product Picture	Series	Part Number and Product Description	Dimensions WxDxH mm
	Accessory	LN-KDG-YKD-1UKN-LG-E 1U 19" cable management panel 5 rings, RAL 7035 Light Grey	482x72x44
	Accessory	LN-KDG-YKD-1UFC-LG-E 1U 19" cable management panel for patchcord entry, brushed type, RAL 7035 Light Grey	482x12x44

19" Economic PDU Module

Product Picture	Series	Part Number and Product Description	Dimensions WxDxH mm
	Accessory	LN-PRZ-EKO-1U6P-SC 1U 19" 6 socket schuko power strip, on/off switched, 3 m cable	482x55x60

Brush Type Cable Entry Panel

Product Picture	Series	Part Number and Product Description	Dimensions WxDxH mm
	Accessory	LN-PM-FR-018 Brush type cable entry panel	145x8x70

Fan Module Thermostat Switched Ball Bearing Long Life 50.000 Hours

Product Picture	Series	Part Number and Product Description	Dimensions WxDxH mm
	Accessory	LN-FAN-ONF-1FWM-LG 1 fan units on/off switched, wall mounting, RAL 7035 Light Grey	346x145x50
		LN-FAN-ONF-2FWM-LG 2 fan units on/off switched, wall mounting, RAL 7035 Light Grey	346x145x50
		LN-FAN-THM-1FWM-LG 1 fan units with thermostatic control unit, wall mounting, RAL 7035 Light Grey	346x175x50
		LN-FAN-THM-2FWM-LG 2 fan units with thermostatic control unit, wall mounting, RAL 7035 Light Grey	346x175x50

19" PANDORA SOHO Series

Width: 540 mm
Depth: 400 mm

Wall Mounting Cabinets

Accessories

Fan Module Thermostat Switched Ball Bearing Long Life 50.000 Hours - Economic			
Product Picture	Series	Part Number and Product Description	Dimensions WxDxH mm
	Accessory	LN-FAN-BB-1FPR-LG 1 way fan module on/off switched, RAL 7035 Light Grey	140x170x40
		LN-FAN-BB-2FPR-LG 2 way fan module on/off switched, RAL 7035 Light Grey	340x140x40
		LN-FAN-BB-1FPT-LG 1 way fan module thermostatic control unit, RAL 7035 Light Grey	140x205x40
		LN-FAN-BB-2FPT-LG 2 way fan module thermostatic control unit, RAL 7035 Light Grey	340x175x40

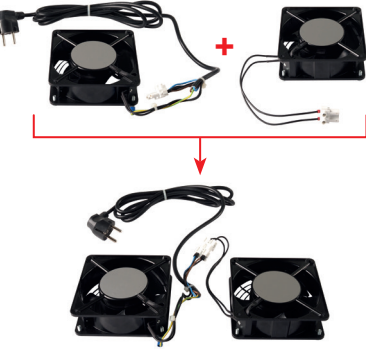
Economic Extendable Modules Fan Modules- No Any Metal Housing Ball Bearing Long Life Fan - 50.000 Hours Economic +			
Product Picture	Series	Part Number and Product Description	Dimensions WxDxH mm
	Accessory	LN-FAN-HL-1FBB-M Single fan with grill, 1,8 meter power cable DIN 49441 schuko plug and extension terminal male, ball bearing long life fan	120x120x38
		LN-FAN-HL-1FBB-E Single fan with grill, extension terminal female ball bearing long life fan	120x120x38

* LN-FAN-HL-1FBB-E is just a fan for making cabinet equipped with 2 fans, used with main product LN-FAN-HL-1FBB-M and add the extension fan.

19" PANDORA SOHO Wall Mounting Cabinet Assembly Guide Video

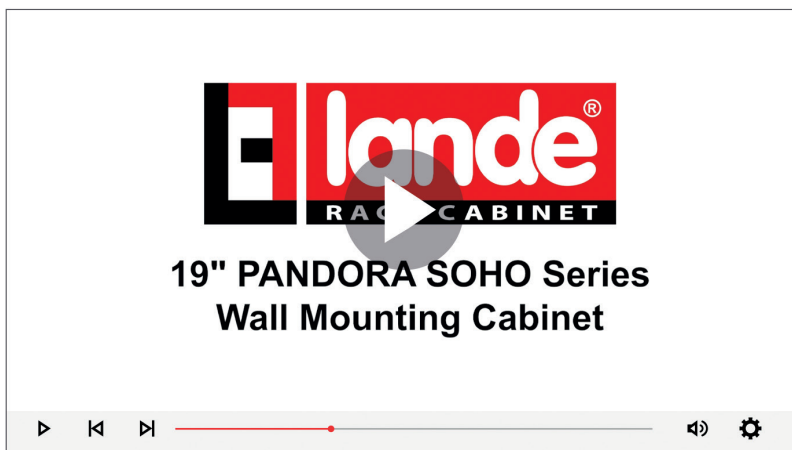

<https://youtu.be/Jr4FkLLkflk>

19" PANDORA SOHO Series

Wall Mounting Cabinets

Assembly Guide

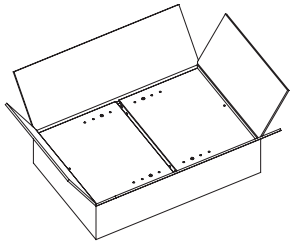

1

Open the box.

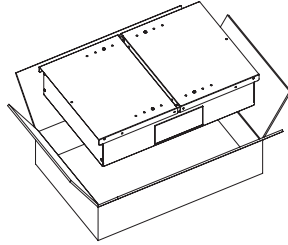

2

Take PANDORA SOHO out of the box.

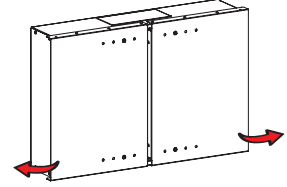

3

Open the hinged side panels.

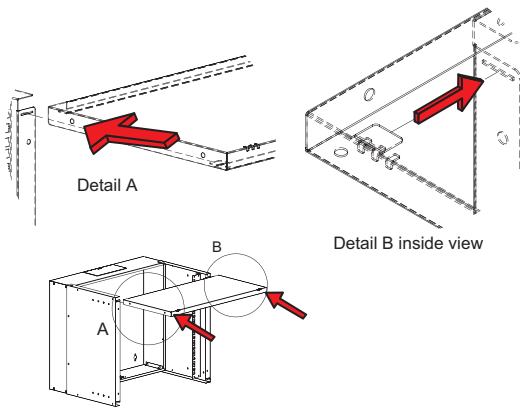

4

Slide the bottom plate onto the body in the direction of the arrows. As seen the details, insert the recess of bottom plate into the gap of the body.

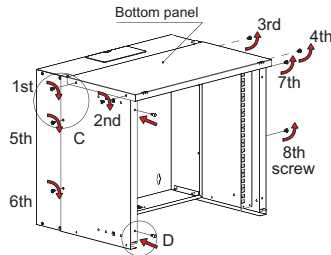

	Screw	Plastic door stopper
4U/7U	4 pcs.	2 pcs.
9U/12U	8 pcs.	2 pcs.

Fix the bottom panel to the body by the screws. (Firstly, the screws placed horizontally needs to be mounted to all cabinet sizes described above. Then, 5th, 6th, 7th and 8th screws need to be mounted vertically placed, for 9U/12U sized cabinets.) Plastic door stopper then needs to be mounted to be on the lock side of the glass door.

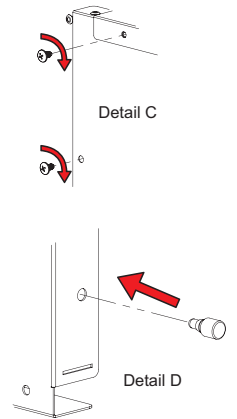

5

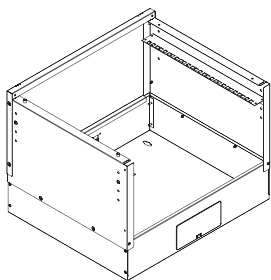

6

Lay the body down and bottom panel to be at the backside.

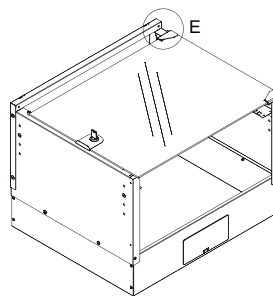

7

Insert the bottom hinge pin of the glass door from the hinge hole of the bottom panel.

19" PANDORA SOHO Series

Wall Mounting Cabinets

Assembly Guide

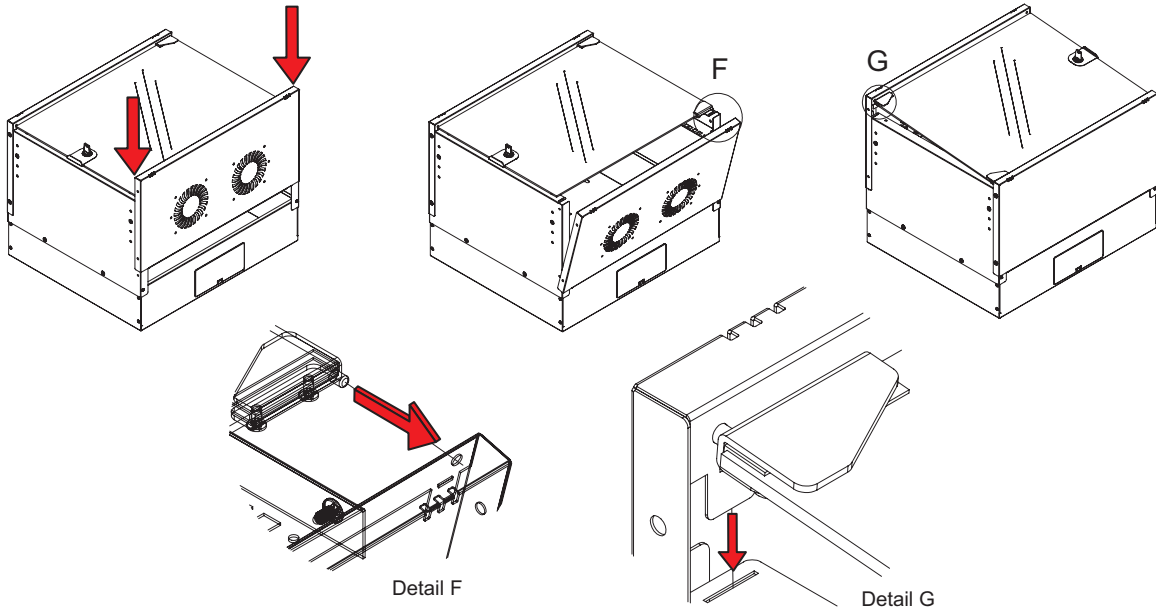

8

Slide the top panel onto the body in the direction of the arrows. (Pay attention that recesses of the top panel not to be inserted to the upper holes of the body). Insert the top hinge pin of the glass door to the hinge hole of the top panel. Insert recesses of the top panel to the panel gap of the body.

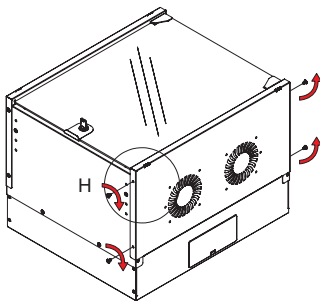

9

Detail H

Assemble the top panel to the body by 4 screws.

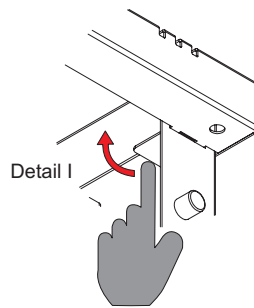

10

Detail J

Put the cabinet on the floor, the bottom panel touching the ground. Bend the recesses of the bottom panel downwards and the recesses of the top panel upwards. Your PANDORA SOHO cabinet is ready to use.

19" PANDORA SLIM Series

Wall Mounting Cabinets

PANDORA SLIM series wall mounting cabinets gives maximum performance on cabling and networking installations the unique design provides economy solution compared to its quality which is based upon high technology fully automated production techniques.

Each cabinet is supplied as standard with a glass front door lockable with a keyed barrel style one point "O" locking unit.



19" W:540 x D:170 mm sizes, a unique feature flexibility of 2U + 3U profiles. For horizontal assembly there are 2U, for vertical assembly there are 3U profile adjustable depths and heights.



Completely standard and stocked product portfolio, being delivered as a single piece assembled product, as shipping configuration 1 set: 4 pieces 19" (2U + 3U) adjustable equipment mounting rails included.

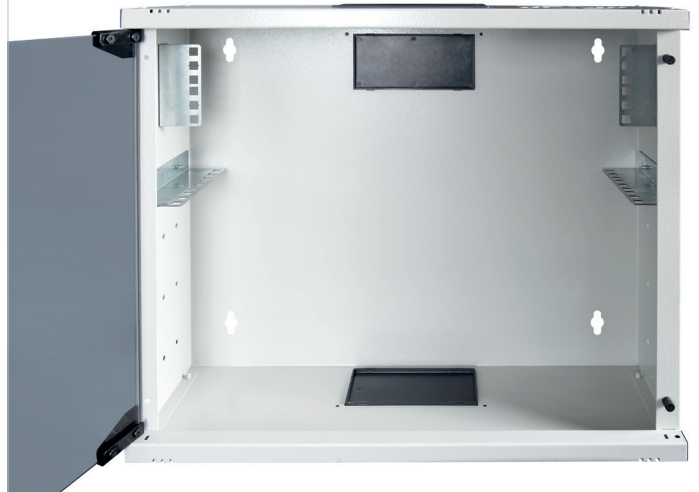

19" PANDORA SLIM Series

Wall Mounting Cabinets

Framework- Top/Bottom Cases:

Multi folded automated bending technology design for framework and top/bottom cases, this provides a heavy-duty structure which results in high load capacity of 60 kg's. Mono block top/bottom cases with the practical, specifically designed click-fit screw set fixed to main framework. Top case has a punched ventilation grill integration of fan housing. (Fan module)

A fan module can be integrated or just single fan could be assembled directly.

Cable entry available in top and bottom case, and one behind door assembly W:145 mm x D:70 mm sized PVC cabling insertions.

Removable PVC cable entry covering with the option of brush strip cover to provide dust protection.

The full length smoked, shatterproof, antistatic, tempered, 4,0 mm thickness safety glass door with single point keyed locking barrel lock system integrated with "O" type locker. Front door opening direction is set right to left, but reversible to left to right at site with removing the hinge system. Hinge System is channel type with screws.

Available/stocked colour of PANDORA SLIM wall mounting cabinets are in RAL 7035 Light Grey, option of Black RAL 9005 colour paint if preferred, coordinate with sales department.

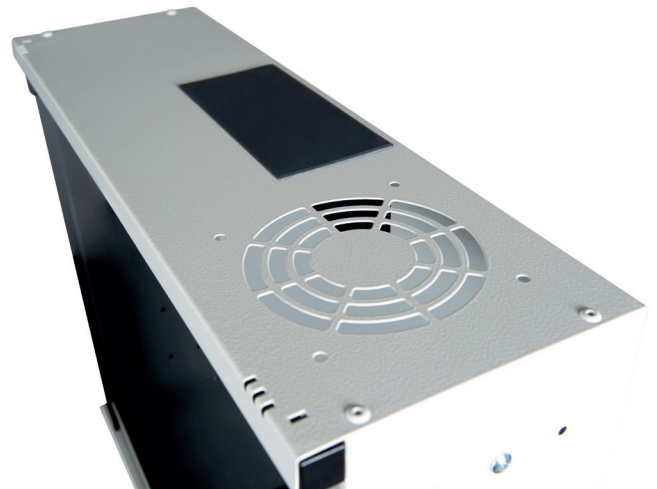

19" PANDORA SLIM Series

Width: 540 mm
Depth: 170 mm

Wall Mounting Cabinets

Construction Drawings

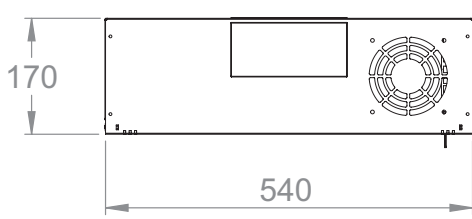

Top view

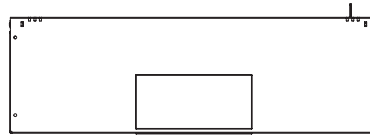

Bottom view

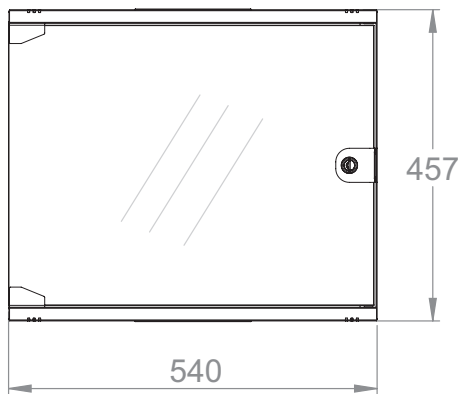

Front view

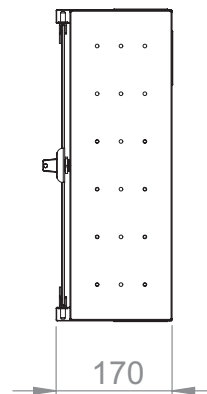

Right side view

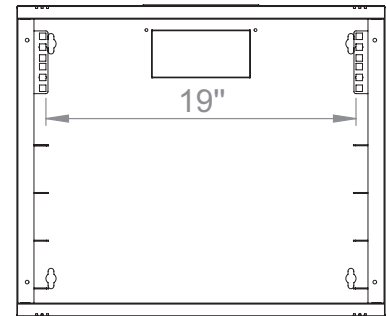

Front inside view

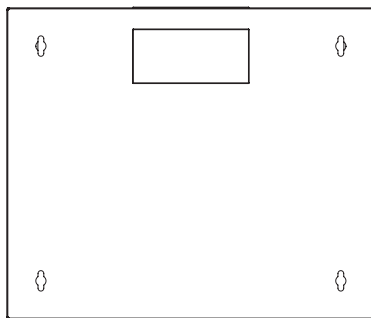

Rear view

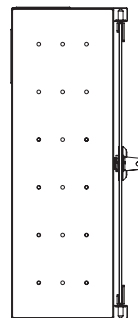

Left side view

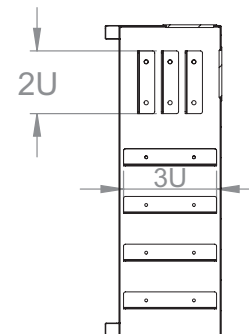

Side inside view

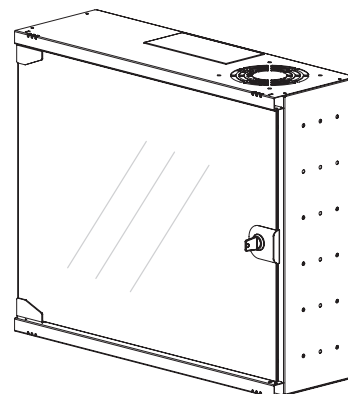
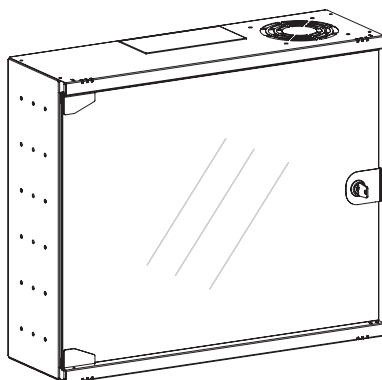

Isometric view

19" PANDORA SLIM Series

Width: 540 mm
Depth: 170 mm

Wall Mounting Cabinets

Construction Drawings

2U 19" mounting rails top view

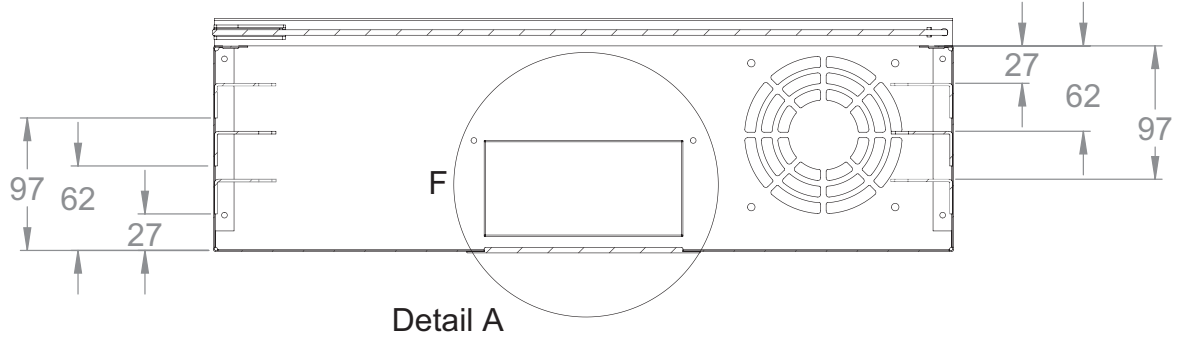

3U 19" mounting rails side view

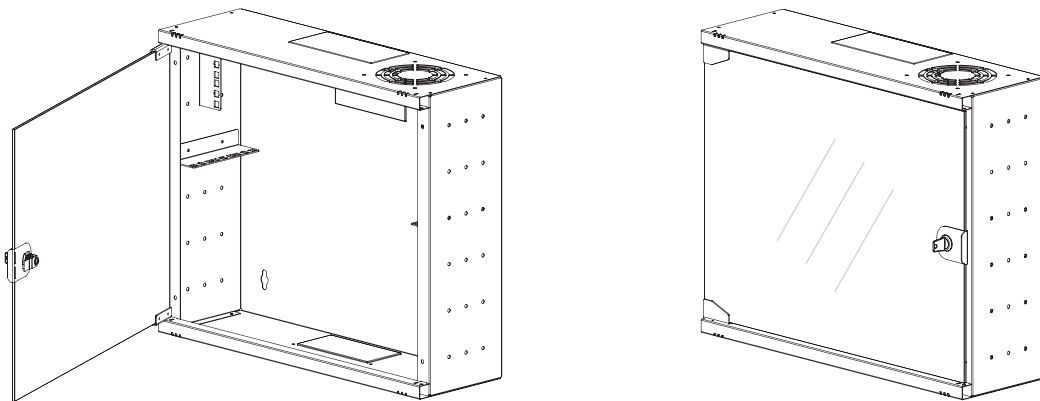
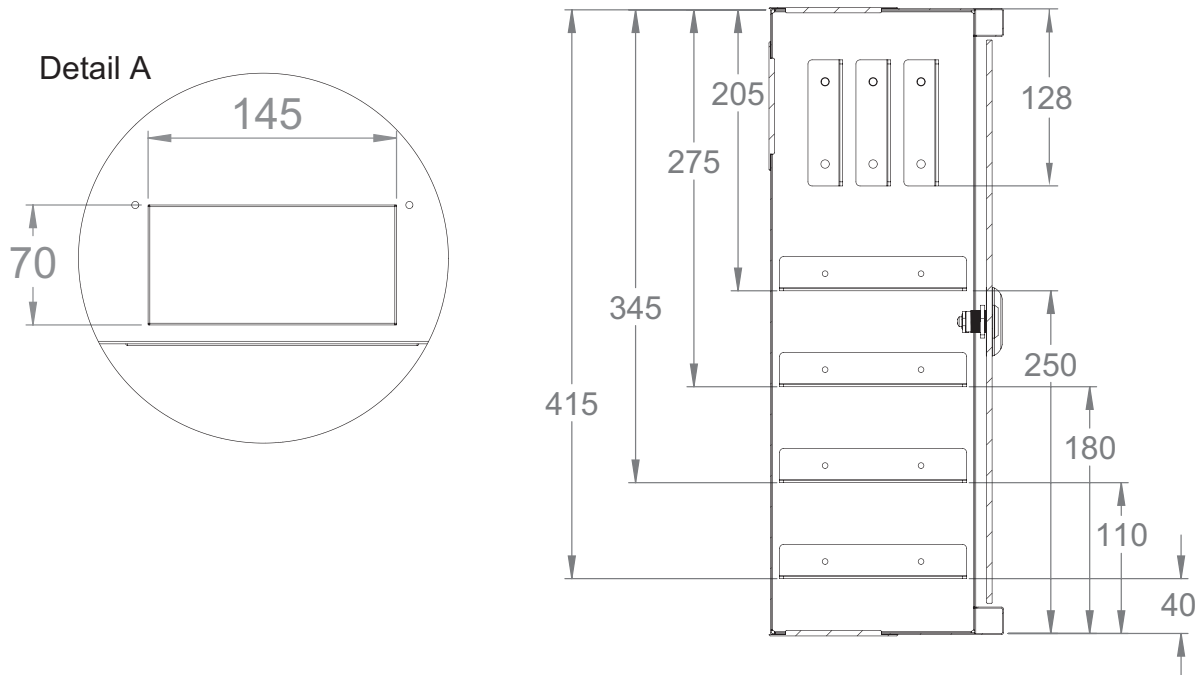

Isometric view

19" PANDORA SLIM Series

Width: 540 mm
Depth: 170 mm

Wall Mounting Cabinets

Construction Drawings

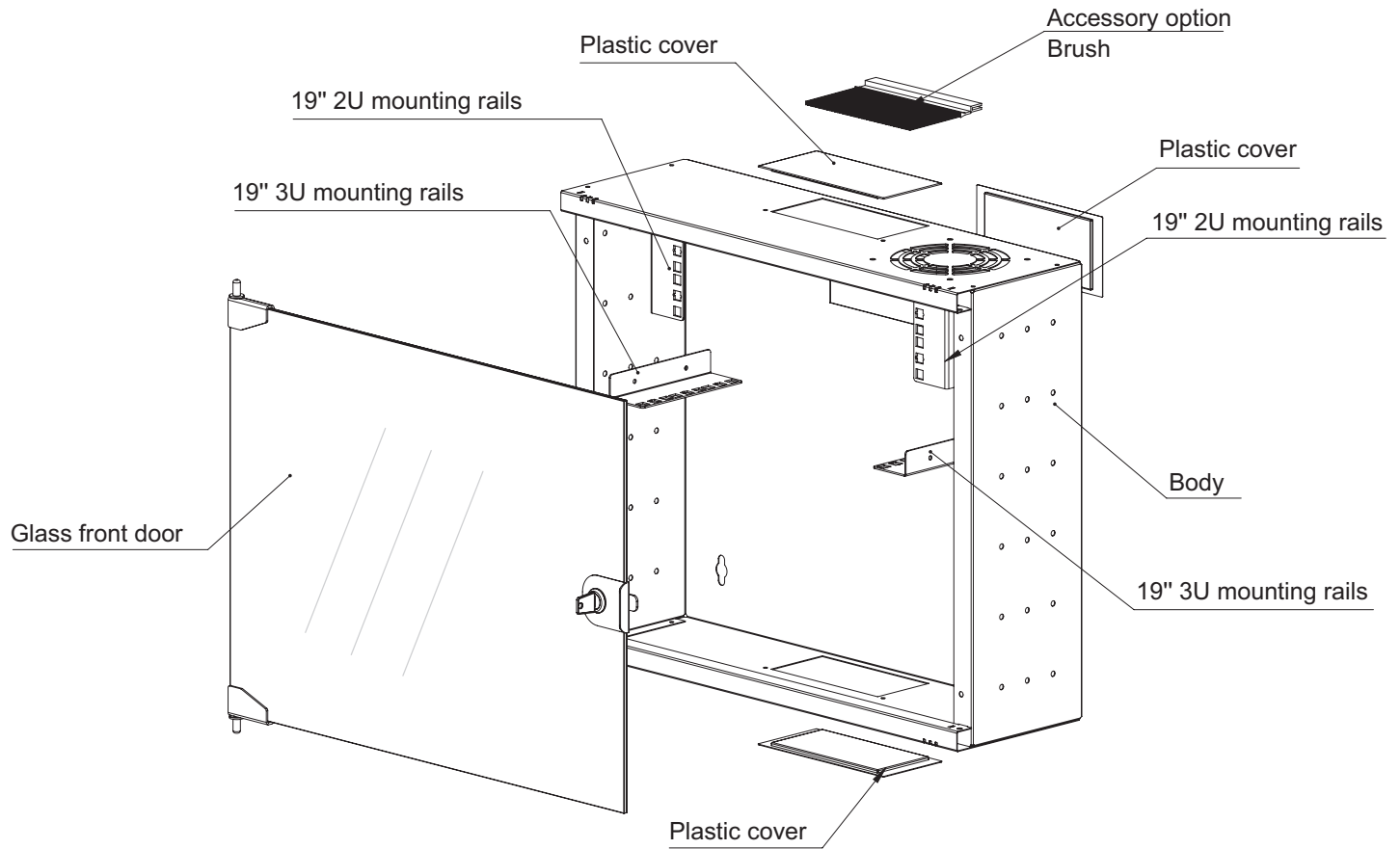

19" PANDORA SLIM Series Wall Mounting Cabinets W=540 mm D=170 mm

Product Code*	Series	Product Description	Dimensions WxDxH mm	h size in U	h mm
LN-SSL541745-LG	PANDORA SLIM Series	19" PANDORA SLIM Wall Mounting Cabinet 3U vertical + 2U horizontal= 5U W=540 mm D=170 mm	540x170x457	3U + 2U	133 + 89

* Cabinet is RAL 7035 Light Grey.



** The product is shipped in assembled packing.

19" PANDORA SLIM Series

Width: 540 mm
Depth: 170 mm

Wall Mounting Cabinets

Accessories

Horizontal Cable Management			
Product Picture	Series	Part Number and Product Description	Dimensions WxDxH mm
	Accessory	LN-KDG-YKD-1UKN-LG-E 1U 19" cable management panel 5 rings, RAL 7035 Light Grey	482x72x44
	Accessory	LN-KDG-YKD-1UFC-LG-E 1U 19" cable management panel for patchcord entry, brushed type, RAL 7035 Light Grey	482x12x44

19" Economic PDU Module			
Product Picture	Series	Part Number and Product Description	Dimensions WxDxH mm
	Accessory	LN-PRZ-EKO-1U6P-SC 1U 19" 6 socket schuko power strip, on/off switched, 3 m cable	482x55x60

Single Fan Module			
Product Picture	Series	Part Number and Product Description	Dimensions WxDxH mm
	Accessory	LN-FAN-HL-1FBB-M Single fan with grill, 1,8 meter power cable DIN 49441 schuko plug and extension terminal male, ball bearing long life fan	120x120x38

Brush Type Cable Entry Panel			
Product Picture	Series	Part Number and Product Description	Dimensions WxDxH mm
	Accessory	LN-PM-FR-018 Brush type cable entry panel	145x70



CONTACT DETAILS

Headquarters

Address:

Merve Mah. Gazi Cad. No: 17 **Phone:** +90 216 312 26 53
Sancaktepe - İstanbul / TURKEY **Fax** : +90 216 312 09 09

Factory

Address:

20. Cadde No: 14 Eskişehir **Phone:** +90 222 236 24 66 pbx
Organize San. Bölğ. 26110 **Fax** : +90 222 236 13 53
Eskişehir / TURKEY

www.lande.com.tr | sales@lande.com.tr

